

# SERVICE INSTRUCTIONS

**Mercotac® connectors contain a small amount of liquid mercury : should be disposed of properly through recycling.**

You can send us our spent units, or dispose of them through an accredited Hazardous waste Company.



M & J Distributors cc  
24 Coleridge Road, Farrarmere  
Benoni, 1501  
Tel. No. : 083 442 2986  
Email: mjdistri@mweb.co.za

1. Mercotac® connectors can be used both horizontally and vertically. However the "UP" arrow on the body of the connector should not point below horizontal. The connectors are reversible so they need not be installed upside down. It is preferable to store units upright (arrow up). <Fig 1>

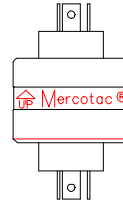

MODEL	BUSHING MOUNTING		BODY MOUNTING	
	A	B	A	B
230	.500(12.7)		.998(25.35)	
331		.40(10.2)		
330	.625(15.87)			
430				
215		.80(20.3)	1.248(31.70)	.80(20.3)
235	.748(19.00)			
1250	3/8(M10)	.70(17.8)		
630	.875(22.22)	.40(10.2)	1.575(40.00)	
335	.984(25.00)	.80(20.3)		
830	1.125(28.57)	.40(10.2)	1.772(45.01)	
435	1.250(31.75)	.80(20.3)		

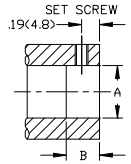

Fig 1

Fig 2 Mounting Dimensions

2. The connector can be held or mounted by the body or plastic bushing, but was not designed to carry mechanical loads. One end should be allowed to float attached only by the connecting wires. In horizontal applications mount the connector with the body rotating to reduce mechanical loads on the bearing and internal components. **Never rigid mount both ends of the connector. This will cause connector failure.** Limit mounting eccentricity to .005" (.13mm). <Fig 2>

3. **Do not solder to the connector or bend tabs excessively as such misuse may cause connector failure and voids the warranty.**

4. Use stranded wires of ample length and flexibility to avoid mechanical loads. Avoid taut wires that pull on the connector. The wires should have enough free play to allow the connector end to rotate approximately ¼ turn. Wires, which allow too much free play, could wrap around the connector. Generally wires are strong enough to restrain the stationary end of the connector. A floating torque arm attached to the stationary bushing may be used if the wires are not adequate. <Fig 3>

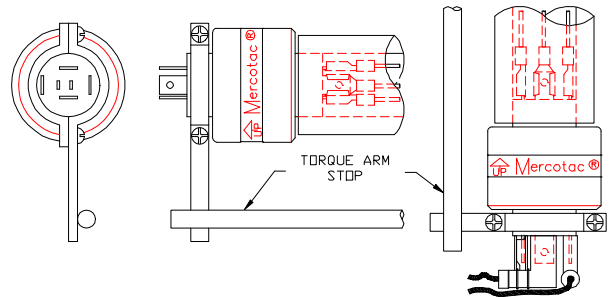

Fig 3 Floating Torque Arm Examples

5. Provide current protection (fuse) on wires attached to connector. Over-current conditions can cause failure of connector. **CAUTION:** The aluminum body may be electrically "hot" after failure. Disable power source before handling a suspected failed connector.

6. The push on terminals (right angle & straight) supplied with the modular connector series use an improved double wall barrel design vs. typical single wall barrel. The extra strength in the barrel improves electrical conductivity and wire grip. Some crimp tools do not have enough leverage to securely crimp this terminal which could cause poor connections. The shape of the crimp die also affects the quality of the crimp, especially for the smaller wire sizes. A recommended crimp tool manufactured by Thomas & Betts is their model #WT112M. The right angle terminals can be configured on the 830 and 630 models as shown. <Fig 4>

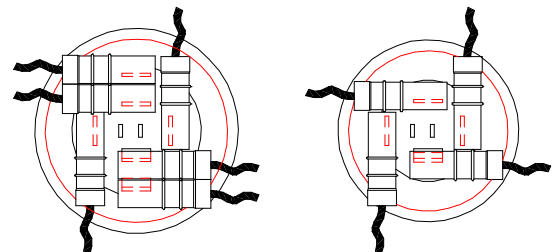

Fig 4 Wire Configuration for Right Angle Terminals

7. Vibration and mechanical shock will reduce service life or cause connector failure. Some installations may require a shock isolating mounting, such as rubber tubing. <Fig 5>

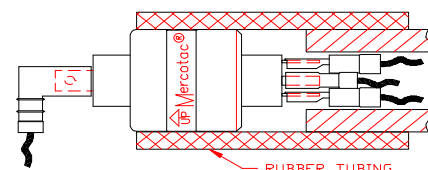

Fig 5 Vibration Isolation

8. The connector contains plastic materials, which are sensitive to heat. Over-heating will cause reduced life or connector failure. Provide thermal insulation where necessary to prevent temperature of the unit from exceeding 140°F (60°C). <Fig 6>

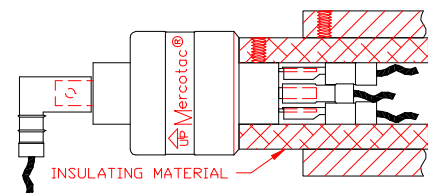

Fig 6 Thermal Insulation

9. **In food packaging applications:** Mercotac® connectors contain liquid mercury and other fluids. **Isolate connector from the food processing area by using a protective housing.** Short circuit failure at or in connection with a Mercotac® connector rarely but occasionally may result in leakage. The use of a protective housing may be advisable in these applications. <Fig 7>

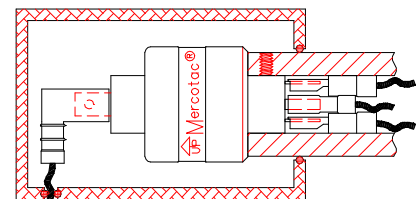
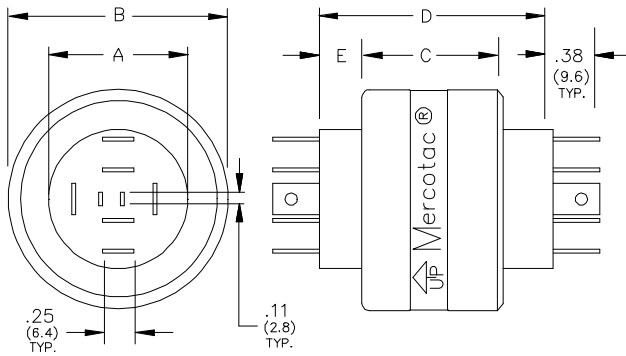

Fig 7 Protective Housing

# MODULAR SERIES



MODEL	A	B	C	D	E
230	.498(12.65)	.996(25.30)	1.10(27.9)	1.82(46.2)	.34(8.6)
331	.498(12.65)	.996(25.30)		2.69(68.3)	.78(19.8)
215-2K	.746(18.95)	1.246(31.65)	1.10(27.9)	2.67(67.8)	.77(19.6)
235	.746(18.95)			2.67(67.8)	.77(19.6)
330	.623(15.82)	1.573(39.95)	1.14(29.0)	1.87(47.5)	.37(9.4)
430	.623(15.82)			1.87(47.5)	.37(9.4)
335	.982(24.94)	1.770(44.96)	1.14(29.0)	2.72(69.1)	.78(19.8)
630	.873(22.17)			2.72(69.1)	.78(19.8)
830	1.123(28.52)	1.770(44.96)	1.14(29.0)	1.84(46.7)	.34(8.6)
435	1.248(31.70)			2.72(69.1)	.78(19.8)
±in(mm)	.002 (.05)	.01 (.25)	.01 (.25)	REF	.01(.25)

## CONTACT TAB ORIENTATION

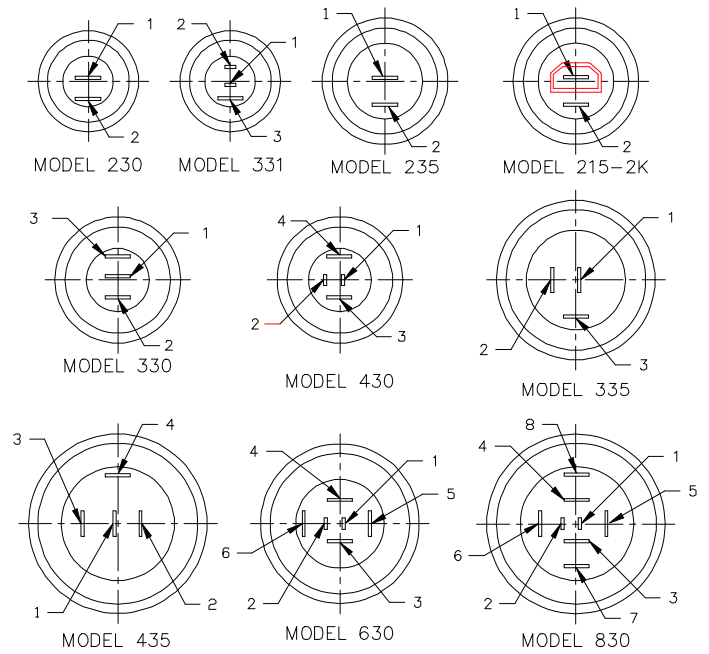

## MODEL 1250

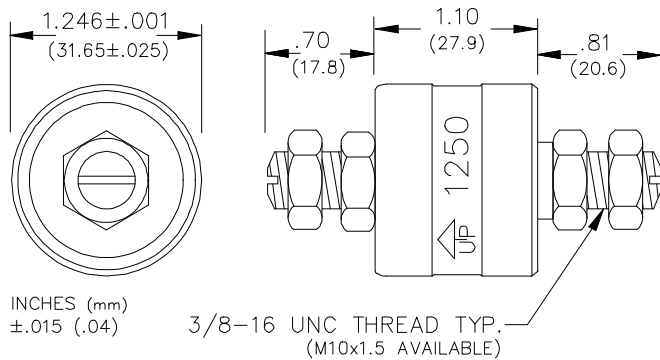

## AVAILABLE DISCONNECTS

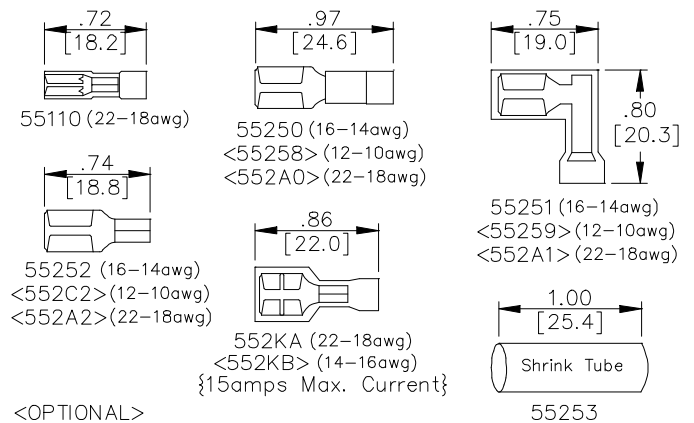

**WARRANTY:** Units are guaranteed for one year from date of purchase against defective materials and workmanship. Replacement will be made except for defects caused by abnormal use or mishandling. All statements and technical information contained herein, or presented by the manufacturer or his representative are rendered in good faith. User must assume responsibility to determine suitability of the product for intended use. The manufacturer shall not be liable for any injury, loss or damage, direct or consequential arising out of the use, or attempt to use the product.

# TECHNICAL SPECIFICATIONS

SPECIFICATIONS		MODEL NUMBER									
	1250	230	330	331	430	630	830	215-2K	235	335	435
NUMBER OF CONDUCTORS	1	2	3	3	4	6	8	2	2	3	4
VOLTAGE RANGE (V) AC/DC			0 - 250V					2000V		0 - 500V	
CURRENT RATING (A) SM TABS				2 SMALL TABS @ 4 AMPS							
CURRENT RATING (A) LG TABS	250	2/30	3/30	1/30	2/30	4/30	6/30	2/15	2/30	3/30	4/30
MAX. FREQUENCY RESPONSE	200 MHz	100 MHz									
MERCURY CONTACT RESISTANCE	< 1 MilliOhm										
MAXIMUM ROTATING SPEED (RPM)	1200	1800	1200	1800	1200	300	200	1200	1200	500	300
MAXIMUM BODY TEMPERATURE	60°C (140°F)										
MINIMUM OPERATING TEMPERATURE	-29°C (-20°F)										
CIRCUIT SEPARATION		> 25 MegOhm			> 50 MegOhm				> 50 MegOhm		
ROTATIONAL TORQUE (Nm X 10 <sup>-4</sup> )	250	200	300	200	400	700	1000	400	400	700	850

## DISCONNECTS / ACCESSORIES

SM. INSULATED (18-22awg)	55110				STD (4)						
LG. INSULATED (18-22awg)	552A0		OPTIONAL							OPTIONAL	
LG. INSULATED (14-16awg)	55250	(2)	OPT *	(1)	(2)	OPTIONAL *		(2)	(3)	(4)	(4)
LG. INSULATED (10-12awg)	55258		OPTIONAL *							OPTIONAL *	
LG. HIGH VOLT (18-22awg)	552KA							(4)		OPTIONAL **	
LG. HIGH VOLT (14-16awg)	552KB							OPTIONAL		OPTIONAL **	
LG. UNINSULATED (18-22awg)	552A2		OPTIONAL							OPTIONAL	
LG. UNINSULATED (14-16awg)	55252		OPT.	(3)	OPTIONAL (4)		(6)			OPTIONAL	
LG. UNINSULATED (10-12awg)	552C2		OPTIONAL							OPTIONAL	
SHRINK TUBE FOR UNINS.	55253		OPT.	(3)	OPTIONAL (4)		(6)	(4)		OPTIONAL	
LG. ANGLE INSUL. (18-22awg)	552A1		OPTIONAL							OPTIONAL	
LG. ANGLE INSUL. (14-16awg)	55251		(2)	(3)	(1)	(2)	(4)	(6)	(2)	(3)	(4)
LG. ANGLE INSUL. (10-12awg)	55259		OPTIONAL							OPTIONAL	
HEX NUT, 3/8-16 BRASS	12580	(4)									
RUBBER BOOT KIT FOR PROTECTION	57125	57230	57430	57230	57430	57630	57830	57235	57235	57335	57435
PLUG KIT (PAIR) PARTS ONLY					50430						
PLUG ASS'Y W/12" WIRES (PAIR)					50431						

\* These optional terminals may require additional clearance and slight bending of tabs.  
 \*\* Fully insulated High Voltage terminals are limited to 15 amps of current.